

NEW LEADER[®]

INSTALLATION INSTRUCTIONS

**Includes Models L4000G4, L2020G4, L3020G4, L3020XP,
L3030G4, L3220G4, L5034G4, 7020 & L2000G4**

EFFECTIVE 09/2013

Revision E



Highway Equipment Company

Building the best since 1939.

**1330 76TH AVE SW
CEDAR RAPIDS, IA 52404-7052
PHONE (319) 363-8281 | FAX (319) 286-3350
www.highwayequipment.com**

Copyright 2009 Highway Equipment Company, Inc.

Hydraulic Requirements 3

Pump and PTO Requirements 3

 Sizing Data Required 3

 PTO Pump Selection 4

Truck Requirements..... 6

Hydraulic Pump Installation 6

Radar & Controller Installation..... 6

Control Valve Installation 6

Mounting of Spreader Body 6

 Truck Frame Length..... 6

 Filler Strips 7

 Rubber Mount Pads 7

 Lifting the Spreader..... 8

 Installing Body..... 9

 Front Mounting Angles..... 9

 Center Mounting Angles 10 & 11 Foot Bodies 9

 Center Mounting Angles 12 to 16 Foot Bodies 9

 Rear Mounting Angles..... 10

 Securing to Frame 11

Spinner Installation 11

Side Board Installation..... 11

Inverted V Installation 11

Fender Installation..... 12

Cooler Hydraulics Installation..... 12

Hydraulic Hose Installation..... 13

 Installation Guide 14

 Hydraulic Drain Lines..... 14

Cooler Connections 15

Electrical Connections 15

Light Installation 15

Spinner Installation 15

Filling Hydraulic System..... 15

Checking Installation 15

Recommended sequence of installation is:

1. Mounting of PTO and pump drive.
2. Installation of radar (if applicable)
3. Mounting of spreader.
4. Installation of controller and encoder (if applicable)
5. Installation of hydraulic hose and electrical wiring.
6. Installation of optional parts.
7. Filling of hydraulic tanks and lubrication.
8. Checking for leaks and proper functioning.

NOTICE! Pump and truck requirements must be determined prior to installation of the spreader.

HYDRAULIC REQUIREMENTS

Hydraulics		GPM (LPM) (Gallons/Liters per Minute)	Maximum Pressure
L4000 MULTAPPLIER Ready		40 (151.5)	3100
L4000 MULTAPPLIER Complete	Spinner & Conveyor	40 (151.5)	3100
	MULTAPPLIER	9 (34)	1500
L4000 High Performance	Spinner	40 (151.5)	3100
	Conveyor	20 (76)	3400
	MULTAPPLIER	20 (76)	1500
L2000G4	Spinner/Conveyor	25 (91)	3100
L2020G4	Spinner and Conveyor	25 (91)	3100
L3020G4	Spinner and Conveyor	40 (151.5)	3100
L3020XP	Spinner	40 (151.5)	3100
	Conveyor	20 (76)	3100
L3030G4	Spinner & Conveyor	30 (113.5)	3100
	MULTAPPLIER	9 (34)	1500
L3220G4	Spinner and Conveyor	40 (151.5)	3100
	MULTAPPLIER	9 (34)	1500
L5034G4	Spinner	40 (151.5)	3100
	Conveyor	27 (102)	3400
7020	Spinner and Conveyor	40 (151.5)	2750

PUMP & PTO REQUIREMENTS

Sizing Data Required:

Since optimal performance depends upon the match between pump size, pump speed (which depends upon engine speed and PTO percent), it is essential that a correct match between these factors be made. This matching is called "sizing."

1. Correct sizing requires accurate and complete information.
 - a. Engine governed operating speed.
 - b. Transmission make and model.
 - c. PTO Data
 1. Make and Model of PTO.
 2. PTO percentage of Engine RPM.
 3. Direction of PTO Rotation (Engine Direction or Opposite of Engine Direction).

NOTICE!

Excessive engine speed will cause more hydraulic oil to be pumped than is required to drive spinners and conveyor and may result in overheating the oil. Too low an engine speed may not provide sufficient hydraulic oil flow to maintain spread width or to keep the conveyor running at the speed required to deliver the desired quantity of material being spread.

NOTE: It may be necessary to select a higher percentage PTO or a larger pump than standard with lower speed engines, such as diesels and heavy duty gasoline engines. Consult your dealer in such cases. It is desirable to install a tachometer in order to maintain proper engine speeds.

2. PTO Pump Selection

NOTICE!

Do not select a PTO % and an engine RPM resulting in more than 3000 PTO RPM. Driving the pumps (referenced below) at speeds greater than 3000 RPM will result in premature failure of the pump and other hydraulic components.

L3020G4 & 7020			
HECO Pump Part Numbers	Pump CID	Theoretical Pump GPM (LPM) 100% Efficiency	Pump RPM
86664	3.85	*40 (151.4)	2350
86665	4.38	*40 (151.4)	2100

* - Requires higher RPM to achieve GPM.

L4000G4			
HECO Pump Part Numbers	Pump CID	Theoretical Pump GPM (LPM) 100% Efficiency	Pump RPM
86664	3.85	*40 (151.4)	2350
86665	4.38	40 (151.4)	2100
304424 (Front Section)	4.46	40 (151.4)	2075
304425 (Rear Section for Insert)	.93	9 (34.1)	
304426 (Rear Section for High Performance Hydraulics)	2.17	20 (75.7)	

* - Requires higher RPM to achieve GPM.

L2020G4 & L2000G4			
HECO Pump Part Numbers	Pump CID	Theoretical Pump GPM (LPM) 100% Efficiency	Pump RPM
86664	3.85	25 (94.6)	1500
86665	4.38	25 (94.6)	1320

L3020XP			
HECO Pump Part Numbers	Pump CID	Theoretical Pump GPM (LPM) 100% Efficiency	Pump RPM
304424 (Front Section)	4.46	40 (151.4)	2075
304426 (Rear Section)	2.17	20 (75.7)	

* - 304424 and 304426 are both required for L3020XP operation.

L3030G4			
HECO Pump Part Numbers	Pump CID	Theoretical Pump GPM (LPM) 100% Efficiency	Pump RPM
304428 (Front Section)	3.19	30 (113.6)	2175
304425 (Rear Section)	.93	9 (34.1)	

* - 304428 and 304425 are both required for L3030G4 operation with MULTAPPLIER.

L3220G4			
HECO Pump Part Numbers	Pump CID	Theoretical Pump GPM (LPM) 100% Efficiency	Pump RPM
304424 (Front Section)	4.46	40 (151.4)	2075
304425 (Rear Section)	.93	9 (34.1)	

* - 304424 and 304425 are both required for L3220G4 operation with MULTAPPLIER.

L5034G4			
HECO Pump Part Numbers	Pump CID	Theoretical Pump GPM (LPM) 100% Efficiency	Pump RPM
304428 (Front Section)	3.19	40 (151.4)	2875
304426 (Rear Section)	2.17	27 (102)	

To determine PTO (Power Take-Off) percentage:
 $(\text{PTO RPM} \div \text{OPTIMAL TRUCK ENGINE RPM}) \times 100 = \text{PTO}\%$

To determine Engine RPM:
 $\text{PTO RPM} \div (\text{PTO}\% \div 100) = \text{Engine RPM}$

TRUCK REQUIREMENTS

In mounting the spreader on a truck, the following major questions must be considered:

1. Is the CA (Cab to Axle) dimension of the truck correct for the length of the spreader?

The Dimensions and Capacities chart in the operator's manual will assist in matching spreader to truck.

2. Is the truck's GAWR (Gross Axle Weight Rating) and the GVWR (Gross Vehicle Weight Rating) adequate to carry the fully loaded spreader?

Refer to your New Leader dealer to find the GAWR and GVWR for most trucks, and how to calculate the weight distribution on each axle and total loaded vehicle weight.

HYDRAULIC PUMP INSTALLATION

HECO pumps are direct mount. See *Pump Hydraulics* parts list in the operator's manual for assembly instructions.

RADAR & CONTROLLER INSTALLATION

See control manual for installation instructions of radar, control box and cable routing.

CONTROL VALVE INSTALLATION - 7020 ONLY

Select a location considering the following:

1. The feedgate control valve handle must be conveniently located for the operation with adequate clearance provided for routing hoses below the cab floor. Refer to "Hydraulics" in *Parts Pages*.
2. The panel must be located so that it will not get in the way of entering or exiting the truck cab.
3. Make sure the panel will not interfere with operation of other truck or equipment controls.
4. Make sure the panel will not catch or snag clothing or parts of body, operator or passengers.
5. Check to ensure wiring and hoses to control panel can be run without interference.

MOUNTING OF SPREADER BODY

**CAUTION**

All holes in truck cab walls, floor and firewall are to be grommeted, plugged and sealed to prevent entrance of engine fumes, dust, dirt, water and noise.

Truck Frame Length

Refer to *Dimensions and Capacities* section in the operator's manual for approximate length from the rear of the cab to the rear end of the frame. Shorten truck frame as necessary, making sure to follow truck manufacturer's specifications so as not to void truck warranty.

Filler Strips

Units with rubber mounting pads do not require wood filler strips—continue to “Lifting the Spreader”. Rubber mounting pads may be ordered.

NOTICE! Do not weld to truck frame; it may void truck warranty.

A level top surface is necessary for mounting. Add steel shim bars or strips the same thickness as fish plates or other obstructions and as wide as the truck frame channel top flange. Shims must be drilled to clear any rivet or bolt heads.

If Unit is Not Equipped with Rubber Mount Pads:

Hardwood filler strips (not supplied) 1” by 3” (2.5 cm x 7.6 cm) must be installed the full length of the truck frame.

Lifting the Spreader**WARNING**

Use only lifting devices that meet or exceed OSHA standard 1910.84 or ASME B30.20-2006. Never lift equipment over people. Never lift unit with anything or anybody in the body. Loads may shift or fall if improperly supported, causing damage to unit, injury or even death.

**CAUTION**

Do not use lifting device to free unit from a chassis, storage stands or frozen ground, or to lift the chassis in any way. Shock loading is prohibited and sudden accelerations should be avoided. Lifting in such a manner could result in damage to unit or injury.

Always inspect unit lift points for signs of wear, cracking, corrosion, gouges, alterations, or distortion.

Always use a sling, spreader bar, or lifting bar that attaches to the lifting points with a minimum of 60 degrees from horizontal. It is preferable to use an "H" style lifting bar that keeps the attaching chains in a near vertical orientation as shown in Figure 1. Operators of lifting devices must be qualified and knowledgeable in their use and application.

Position the chassis with adequate room around the unit. Work in an environment that permits clear communication to others nearby. Keep area clear of persons when loads are to be lifted and suspended. Do not allow the lifted load to come in contact with any obstruction.

Store units on a solid surface using appropriate storage stands when not installed.

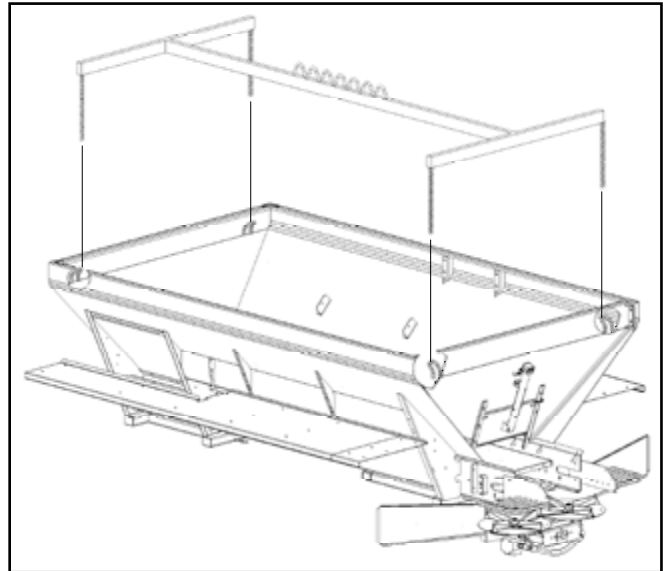

Figure 1 - Lifting Bar

Installing Body**CAUTION**

Make sure drill will not puncture gas tank or harm any other obstruction before drilling holes!

NOTICE!

DO NOT WELD ON VEHICLE FRAME! Such welding can lead to fatigue cracking and must be avoided.

NOTICE!

DO NOT PUT HOLES INTO TOP OR BOTTOM FLANGES—to do so may void truck manufacturer's warranty. When drilling holes in frame member, drill only through vertical web portions.

NOTICE!

Connect welders ground directly to one of the items being welded anytime an arc welder is used on the vehicle or anything connected to the vehicle. Disconnect power cable and ground from control box! Failure to do so can result in damage to components on both the vehicle and/or spreader, in which case the warranty will be null and void by manufacturer.

Front Mounting Angles - All Models

Assemble two front mounting angle springs and hardware. Use a 3/8" (10mm) shim between cross tube mounting plate and truck frame mounting angle. Position assembly under second cross tube from front and against truck frame, make sure springs do not contact cross tube. Mark position of mounting angle holes on truck frame. Drill 9/16" (14mm) holes where marked and install mounting assembly using 1/2" hardware supplied. Weld mounting plate to bottom of cross tube on three sides, and remove 3/8" (10mm) shim (Figure 2). Tighten spring assembly until spring compressed height is 4" (102cm). There should be a 3/8" (10mm) space between cross tube mounting plate and truck frame mounting angle (Figure 2). Repeat this procedure on other side of truck frame, on same cross tube.

NOTE: It may be necessary to mount front mounting angle springs on first cross tube on some vehicles due to obstructions such as spring shackles, etc.

Center Mounting Angles - L4000G4, L3030G4, & L5034G4 ONLY

Position center mounting angles at second cross tube from rear with slotted faces against truck frame and mark location of slots on truck frame. Drill 9/16" (14mm) diameter holes through truck frame, approximately (19mm) from bottom of slots (Figure 2). Weld mounting angle to bottom of cross tube on 3 sides (Figure 4). Install hardware and tighten to recommended torque.

Center Mounting Angles - All Other Models [10 Foot (305cm) and 11 Foot (335cm Bodies)]

Position center mounting angles at a convenient cross tube near center of body with slotted faces against truck frame. Weld mounting angle to bottom of cross tube on three sides (Figure 3). Do not install hardware, these mounting angles are for side to side support only.

Center Mounting Angles - All Other Models [12 Foot (366cm) to 16 Foot (488cm Bodies) as applicable]

Position center mounting angles at a convenient cross tube near center of body with slotted faces against truck frame and mark location of slots on truck frame. Drill 9/16" (14mm) diameter holes through truck frame, approximately 3/4" (19mm) from bottom of slots (Figure 3). Weld mounting angle to bottom of cross tube on three sides (Figure 4). Install hardware and tighten to recommended torque.

NOTE: Position of center mounting angles will vary due to obstructions such as spring shackles, etc.

Rear Mounting Angles - All Models

Position rear mounting angles with the slotted faces against the side of the truck frame and centered on rear cross sill. Mark slot locations on truck frame. Drill 9/16" (14mm) diameter holes through truck frame at bottom end of slots (Figure 3). Weld mounting angle to bottom of cross tube on three sides (Figure 4). Install hardware and tighten to recommended torque.

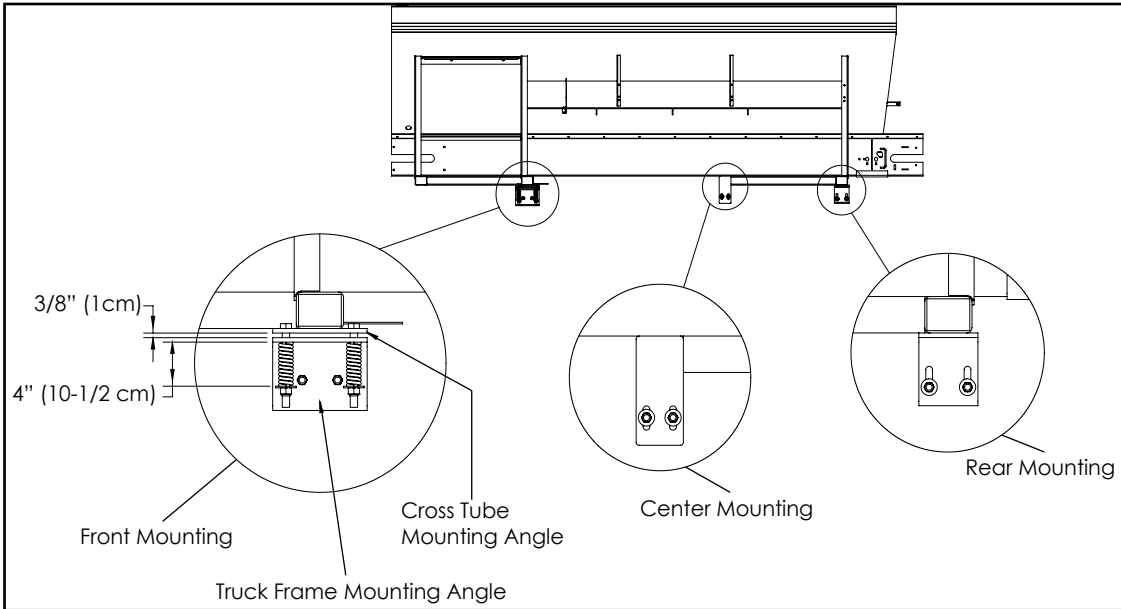

Figure 2 - Mounting Angle Installation - L4000G4, L3030G4, & L5034G4 ONLY

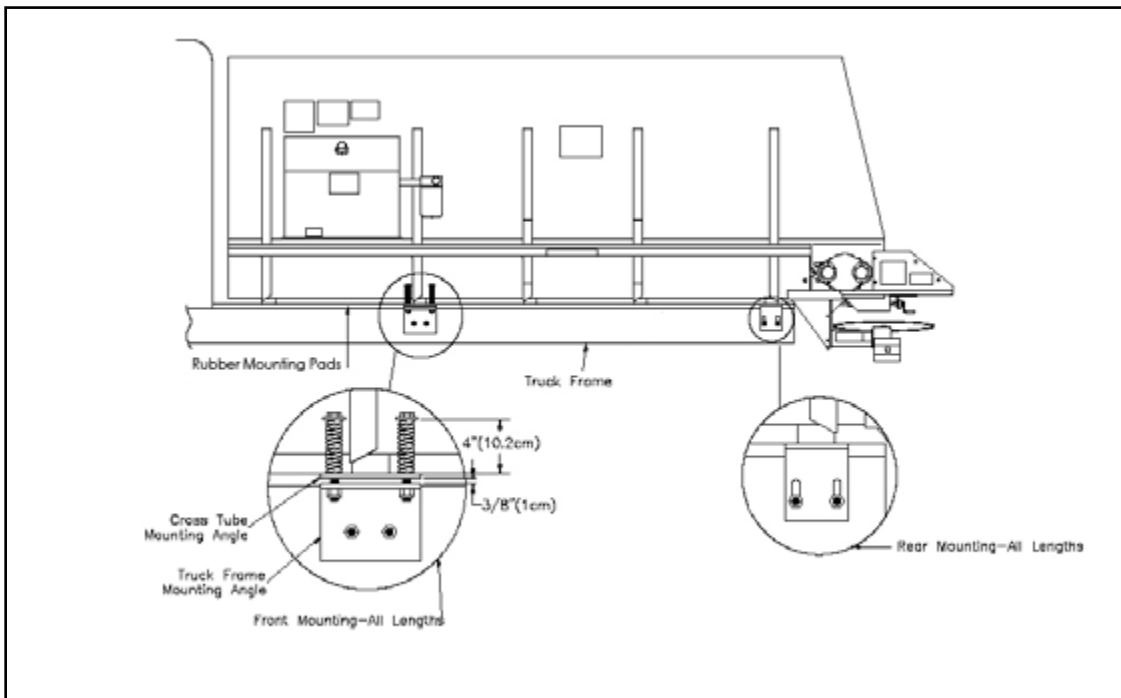

Figure 3 - Mounting Angle Installation - All Other Models

INSTALLATION

Securing to Frame

Install mounting angles and tighten mounting bolts to recommended torque. Weld mounting angles to spreader cross tubes by welding on front, outer and rear sides (Figure 4). Make sure welds between mounting angles and spreader cross tubes are sound full fillet welds. Center mounting angles on tubes (as shown in Figure 4) so full fillet welds can be made on three sides. An edge bead weld is not a satisfactory weld for this service. Use E70S rod/wire for carbon steel, 309 rod/wire for 409 steel and 308 weld rod on 304 stainless steel.

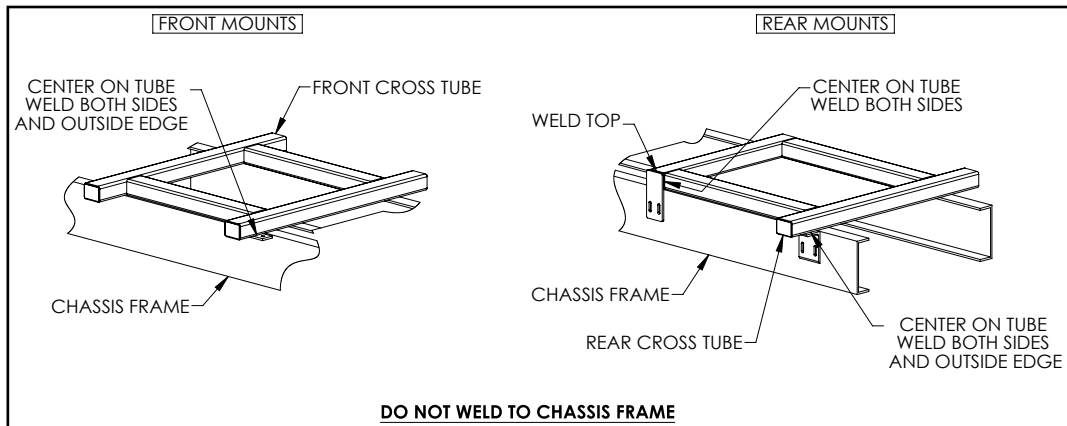

Figure 4 - Welding Instructions

SPINNER INSTALLATION

See *G4 Spread Pattern* tabbed section in the operator's manual if applicable.

SIDE BOARD INSTALLATION (L4000G4, L3030G4 & L3220G4 only)

NOTICE! Sideboards are for use with fertilizer only.

See *Side Board* or *Side Board Mount (Wood)* parts list in the operator's manual for availability and illustrations.

INVERTED V INSTALLATION

See *Inverted V* parts list in the operator's manual for illustration of both typical and high yield installation.

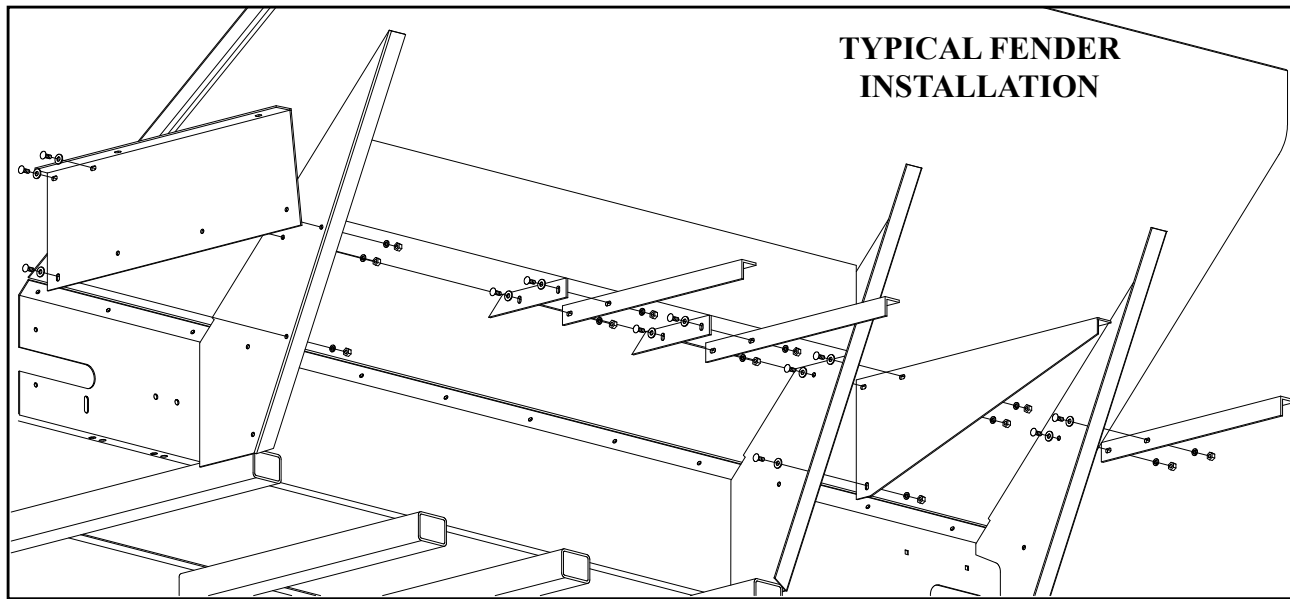
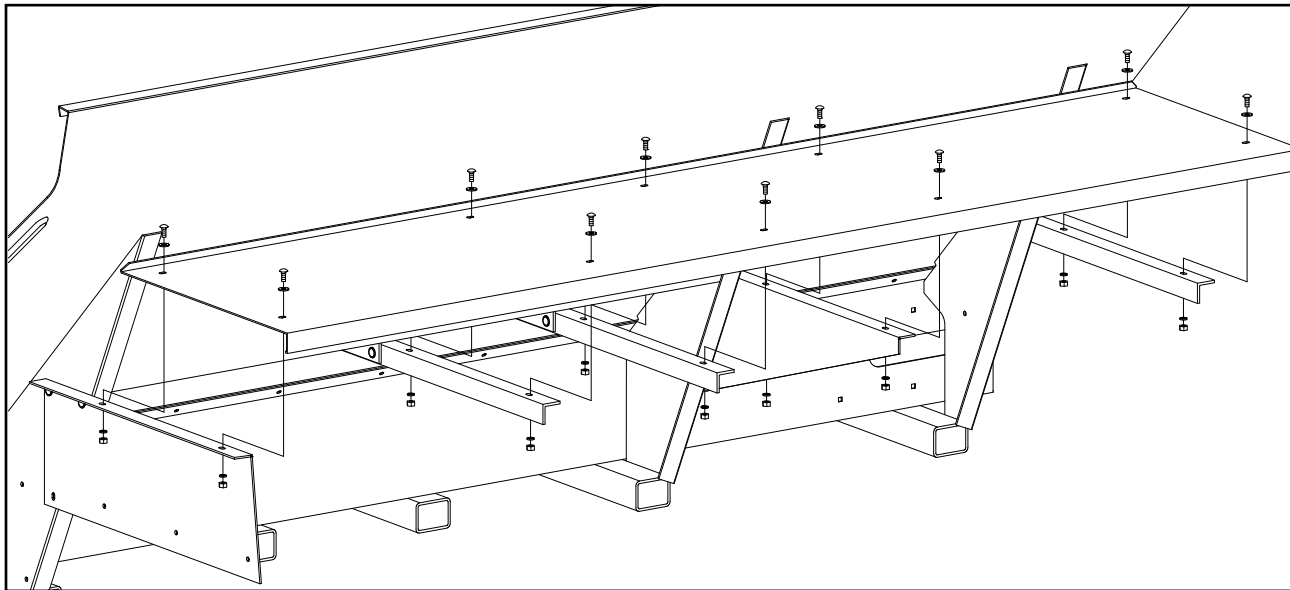
FENDER INSTALLATION***Figure 5 - Fender Angle Installation*****Figure 6 - Fender Installation**

* - Fenders may not be as shown

Attach fender angles and panels in lower holes for 96" and 108" fenders and upper holes for 124" and 132" fenders on spreader body stakes as shown in Figure 5. Do not tighten hardware at this time.

Attach fenders on top of angles/panels as shown in Figure 6. Tighten all hardware.

HYDRAULIC HOSE INSTALLATION**CAUTION**

If a threaded connection is tightened too tightly, the fitting or housing into which the fitting is placed could be distorted and an unstoppable leak could occur.

**WARNING**

Do not use one manufacturer's hose with another manufacturer's fittings! Such will void any warranty and may cause premature burst or leak of hydraulic fluids! Severe injury and/or fire could result!

Determine pressure port of pump. Install pressure hose into this port as shown in Figure 7. Connect suction hose to opposite port and to tank outlet on reservoir. Use plastic tie straps as necessary to support hoses so they will not catch on field obstructions or contact hot or moving parts.

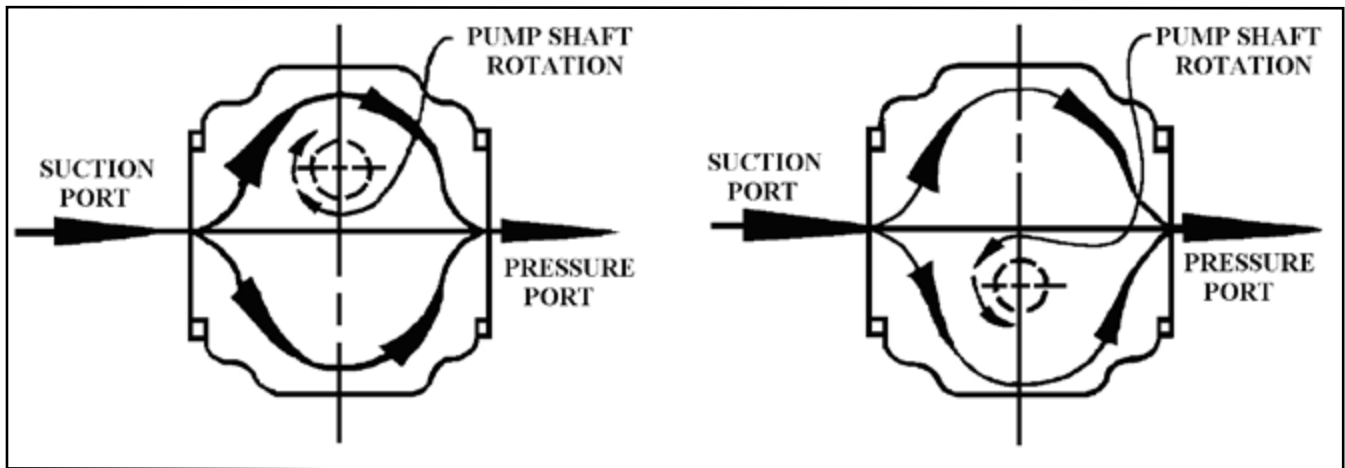

Figure 7 - Hydraulic Pump Installation



Use thread sealer on all fittings, except "O" ring and JIC adapters, "O" ring valves and motors, etc. When using thread sealer, do not put it on the first three threads of the fitting. Too much on the fitting or on the first three threads will force it into the oil stream where it could damage the system.

Assemble system as shown in *Hydraulics* parts list in the operator's manual. Place hose clamps as needed to keep hoses away from hot or moving parts. Do not let hoses hang so low as to be snagged. Do not stretch hoses tight.

Hydraulic hoses are as follows:

- Pressure Line: Four wire braided hose. High pressure hose supplied by dealer.
- Suction Line: Single spiral wire reinforced to be cut to length. Fittings to be assembled with double hose clamps.
- All Return Lines: Double cotton braid with crimped end fittings.

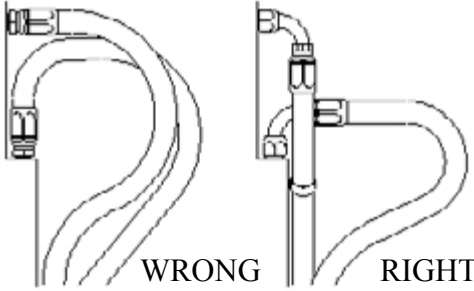
Installation Guide

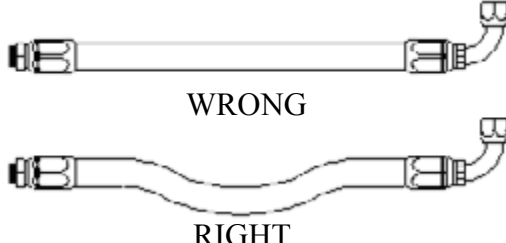
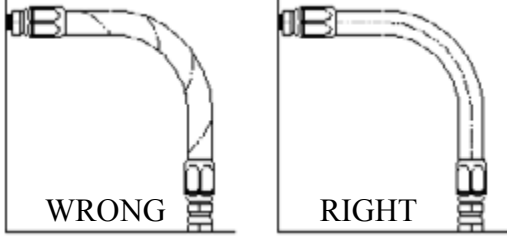
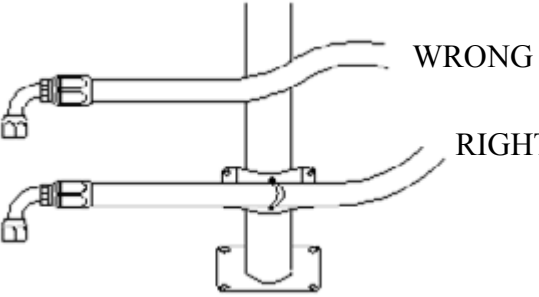
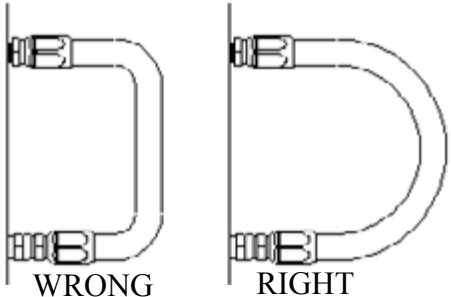
	
<p>1. Use elbows and adapters in the installation to relieve strain on the assembly, and to provide easier and neater installations that are accessible for inspection and maintenance. Remember that metal end fittings cannot be considered as part of the flexible portion of the assembly.</p>	<p>2. Install hose runs to avoid rubbing or abrasion. Clamps are often needed to support long runs of hose or to keep hose away from moving parts. It is important that the clamps be of the correct size. A clamp that is too large will allow the hose to move in the clamp causing abrasion at this point.</p>
	
<p>3. In straight hose installations allow enough slack in the hose line to provide for changes in length that will occur when pressure is applied. This change in length can be from +2% to -4%.</p>	<p>4. Do not twist hose during installation. This can be determined by the printed layline on the hose. Pressure applied to a twisted hose can cause hose failure or loosening of the connections.</p>
	
<p>5. Keep hose away from hot parts. High ambient temperature will shorten hose life. If you cannot route it away from the heat source, insulate it.</p>	<p>6. Keep the bend radii of the hose as large as possible to avoid hose collapsing and restriction of flow. Follow catalog specs on minimum bend radii.</p>

(Used with the permission of The Weatherhead Company.)

Hydraulic Drain Lines

See *Gear Case Drain Lines*, *Reservoir Hydraulics*, and *Pump Hydraulics* parts lists in the operator's manual for illustrations.

INSTALLATION

FILLING HYDRAULIC SYSTEM**NOTICE!**

DO NOT attempt to run pump without first filling hydraulic oil reservoir and opening suction line gate valve, or pump may be ruined.

Fill reservoir with hydraulic oil as specified in the *Lubrication & Maintenance* section in the operator's manual. Be sure oil is clean, free from dirt, water and other contaminants.

Lubricate all points requiring lubrication per "Lubrication Chart" in *Lubrication & Maintenance* section of operator's manual.

COOLER CONNECTIONS

Figure 8 - Cooler Relay

The cooler fan requires 12-volt power to operate, fuse size 30 amp. Attach power cable (Figure 8) to switched power circuit. Connect red wire to battery positive and blue wire to ground.

ELECTRICAL CONNECTIONS

Connect all electrical control circuits. The supply conductor should be connected directly to switched power circuit. All wiring should be approved automotive insulated wire, supported adequately with insulating ties or straps, and located where it will not interfere with any control or access. Make sure wiring does not contact any moving parts or sharp edge and is kept away from any hydraulic line or any heated part.

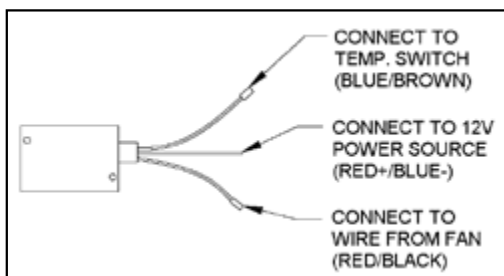
LIGHT INSTALLATION**CAUTION**

All holes in truck cab walls, floor and firewall are to be grommeted, plugged and sealed to prevent entrance of engine fumes, dust, dirt, water and noise.

Light installation must comply with all applicable requirements prescribed by FMVSS/CMVSS 108, ASABE S279, state and local regulations. See *Light's* parts page in the operator's manual for illustrations if applicable.

SPINNER SENSOR

The spinner sensor must be mounted under the right-hand spinner disc in holes provided. Rotate disc so one of the cap screws is directly above the sensor. Position sensor 1/8" (3mm) or less below cap screw and tighten sensor hardware. If the distance between the sensor and spinner cap screw is more than 1/8" (3mm), the sensor may not get a good RPM reading. See *Spinner Sensor* parts list in the operator's manual for illustration.

CHECKING INSTALLATION

See *Initial Start-Up* procedure in the operator's manual.